

The Patco Group is an authoriz

BP333 PLUS ITEM LIST



Better Packages, Inc.®

Shelton, CT 06484

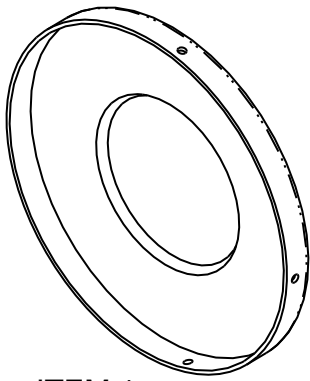

ITEM 1
FM-80 - DRUM

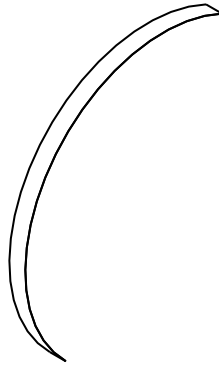

ITEM 2
FM-79 - SCALE NAMEPLATE

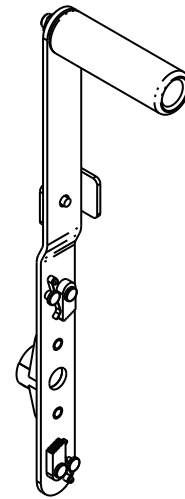

ITEM 3
FM-41-FX
ASSY, CRANK/PAWL/HANDLE

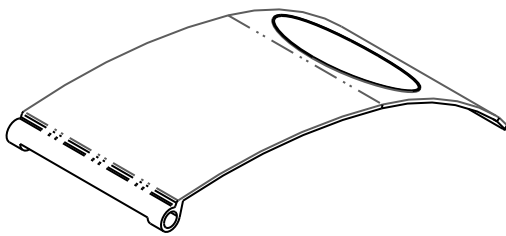

ITEM 4
FM-4 - COVER

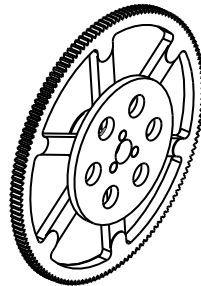

ITEM 5
GE-79-X - ASSY, DRIVE GEAR

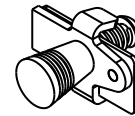

ITEM 6
FM-110-XX
FEED STOP ASSY

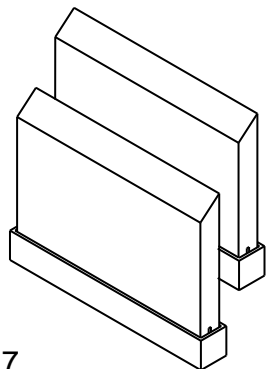

ITEM 7
PW-107A-K - BRUSH KIT

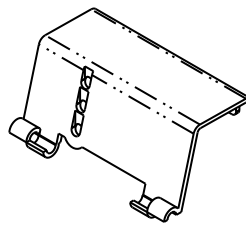

ITEM 8
FM-3 - LOWER FRONT COVER

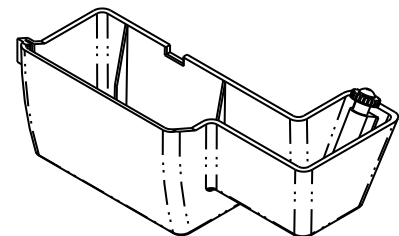

ITEM 9
FM-6-AX - TANK ASSY

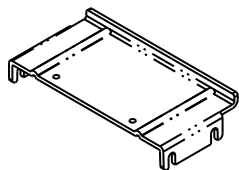

ITEM 10
FM-40 - TANK SHELF



ITEM 11
A-47 - RUBBER FOOT

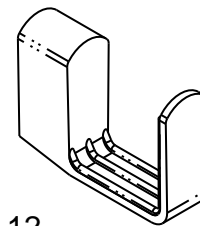

ITEM 12
FF-612-P - BOTTLE BRACKET



ITEM 13
FM-64 - SPRING

BP333 PLUS ITEM LIST

The Patco Group 718-497-1527 info2@patcogroup.com



Shelton, CT 06484

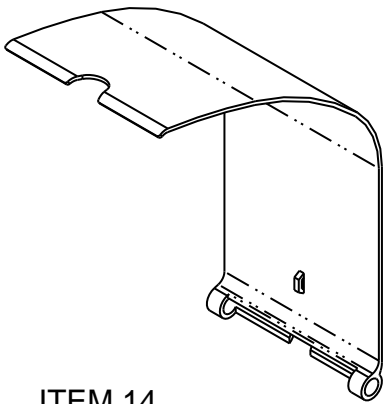

ITEM 14
FM-5 - COVER

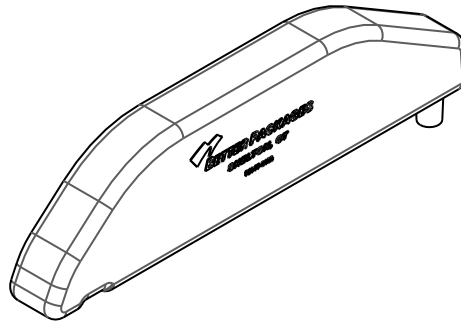

ITEM 15
FF-610-0 - WATER BOTTLE

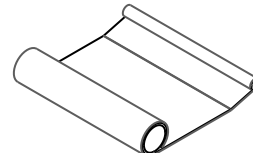

FM-16-X

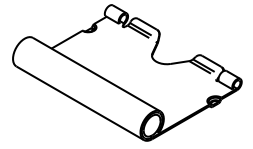

TS33-006-01
TS33-006-02

ITEM 16
PRESSURE PLATE ASSY

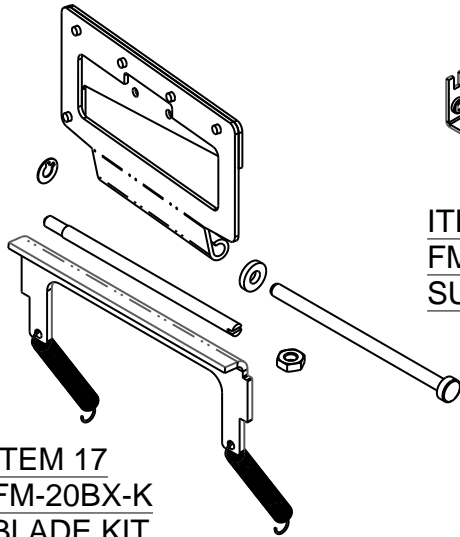

ITEM 17
FM-20BX-K
BLADE KIT

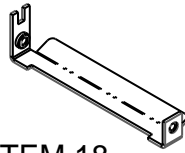

ITEM 18
FM-130-JX
SUPPORT BRACKET



ITEM 19
FM-18A - SHEAR GUIDE
ROLLER, WIDE

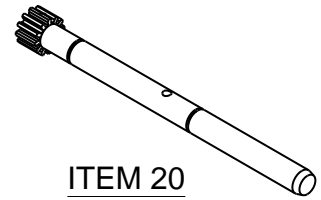

ITEM 20
FM-49-X
SHAFT PINION SUB-ASSY



ITEM 21
E555-065-00
URETHANE FEEDWHEEL

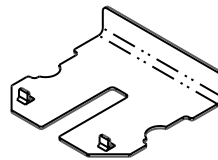

ITEM 22
FM-12-EL - UPPER TAPE PLATE

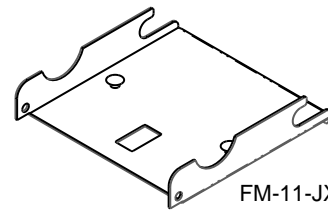

FM-11-JX

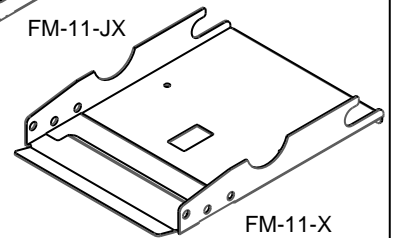

FM-11-X

ITEM 23
LOWER TAPE PLATE

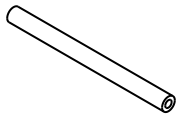

ITEM 24
FM-117 - TIE ROD

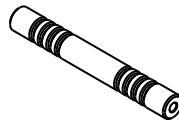

ITEM 25
FM-56 - TIE ROD SLOTTED

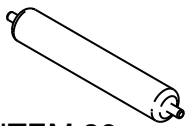

ITEM 26
FM-59-X
TAPE ROLLER ASSY

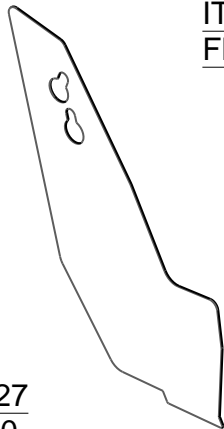

ITEM 27
FM-310
ROLL GUIDE, UNIVERSAL

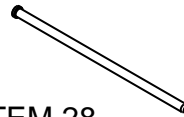

ITEM 28
FM-15 - SUPPORT ROD

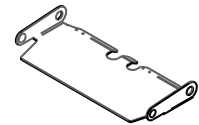

ITEM 29
FM-126J - JPLATE

BP333 PLUS ITEM LIST



Shelton, CT 06484



ITEM 30
FM-48-AX
SPRING HOOK SUB-ASSY

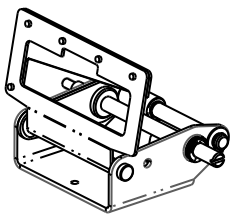

ITEM 31
FM-26-XXX - ROCKER SUB-ASSY

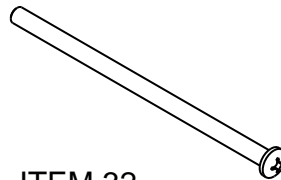

ITEM 32
FM-61 - TIE SCREW

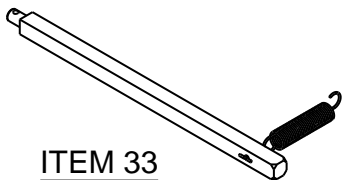

ITEM 33
FM-108-X
ROCKER STOP BAR ASSY



ITEM 34
0010500 - WOOD SPOOL

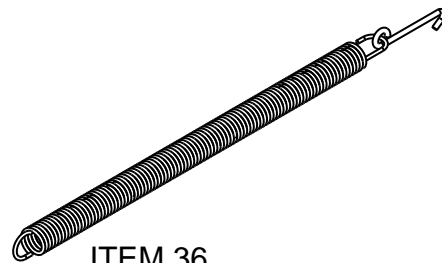

ITEM 36
FM-33-AX
SPRING HOOK ASSY

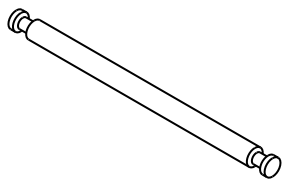

ITEM 37
FM-67 - PULLEY SHAFT

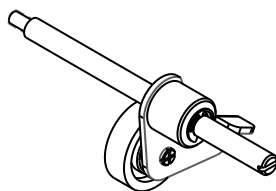

ITEM 38
FM-39-XXX
IDLER SHAFT SUB-ASSY

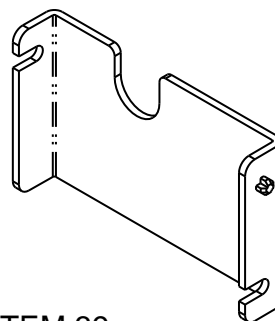

ITEM 39
FM-58P - VERTICAL TIE PLATE

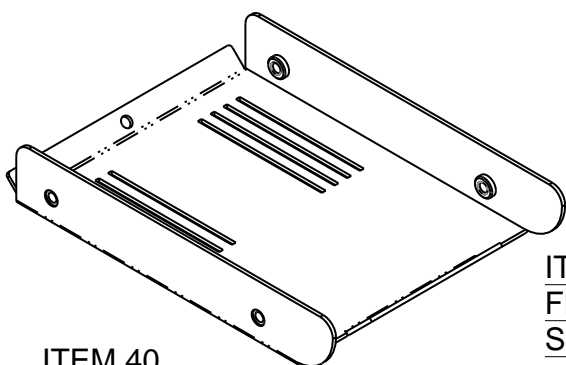

ITEM 40
FM-57X - BASKET

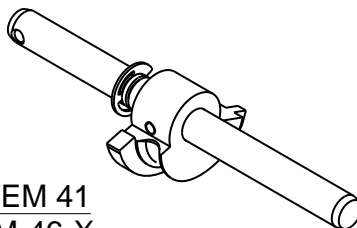

ITEM 41
FM-46-X
SHAFT CAM ASSY



ITEM 42
0235190 - ROLL PIN 3/16 x 1"

BP333 PLUS ITEM LIST

The logo for Better Packages, Inc. is a stylized black arrow pointing to the right. To its right is the text "Better Packages, Inc." in a bold, sans-serif font. Above the company name is the phone number "718-497-2272" and the website "www.betterpackages.com".

Shelton, CT 06484

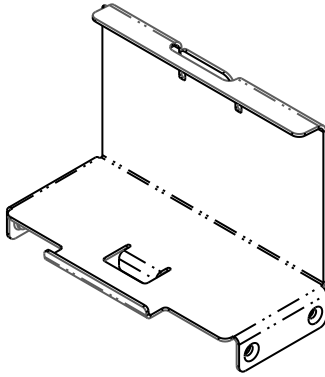

ITEM 43
TS33-032-01 - SAFETY BAFFLE
(4 PIECES OF ST-1949, SCREW-#10-24 x 3/8" LG)

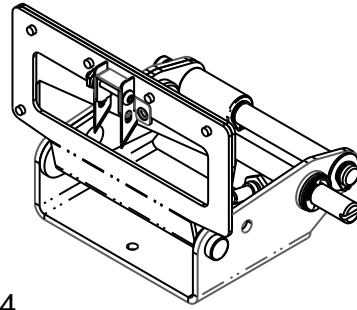

ITEM 44
FM-26-XXX-EZ
ROCKER BLADE W/TAB CUTTER SUB-ASSY

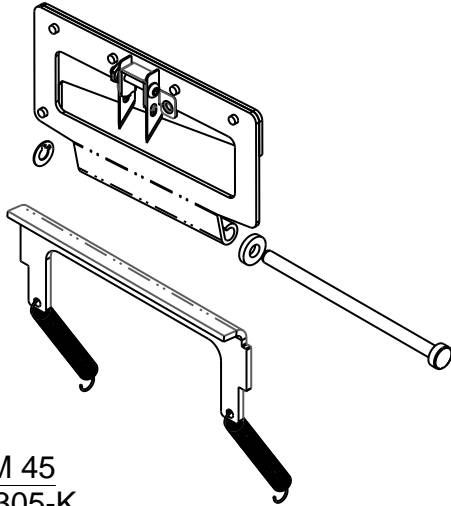

ITEM 45
FM-305-K
TAB CUTTER SHEAR BLADE KIT

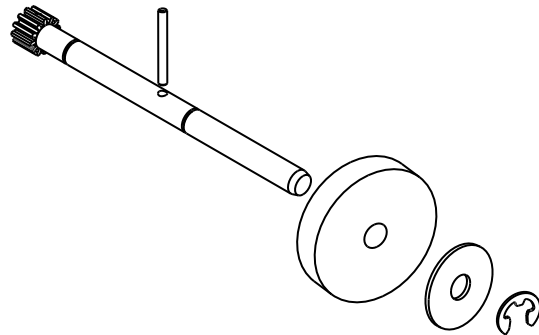

ITEM 46
FM-304-K
FEED WHEEL CONVERSION KIT

BP333 PLUS ITEM LIST

The Better Package, Inc. 1-800-497-1270 www.betterpackage.com
Better Packages, Inc.
Shelton, CT 06484